



11180 Ranchette Dr., Jackson, CA 95642 USA (209) 223-1090 www.confabinstrumentation.com

MODEL 850I / 850S

Turbidimeter

Installation & Instruction Manual

(for use with Serial #1242 and lower, sold on or before 6/28/2015)

MODEL 850I / 850S
Turbidimeter
Installation & Instruction Manual
(for use with Serial #1242 and lower, sold on or before 6/28/2015)

CONFAB INSTRUMENTATION
11180 Ranchette Dr.
Jackson CA 95642
(209) 223-1090
www.confabinstrumentation.com

Date: 11/14/2011

TABLE OF CONTENTS

1. PRINCIPLE OF OPERATION	1
2. INSTALLATION	2
A. Insertion-Type Sensor	2
Dimensions	2
Insertion	4
Removal.....	5
B. Submersible-Type Sensor.....	6
Dimensions	6
Installation.....	6
C. Electronic Signal Converter	7
Dimensions	7
3. WIRING	9
A. General.....	9
B. Wiring Diagram.....	10
C. Alarm Unit Connections and Adjustments (Optional)	11
4. CALIBRATION	12
A. General.....	12
B. Laboratory	14
C. Output.....	15
D. Calibration in Units Other Than NTU	16
5. SENSOR REMOVAL/REINSTALLATION (w/Insertion Adapter Kit)	17
6. TROUBLESHOOTING	18
7. TECHNICAL SUPPORT	19
8. TECHNICAL DIAGRAMS	20
A. Model 850 Turbidimeter	20
Model 850 Circuit Diagram (DC Power)	20
Model 850 Circuit Diagram (AC Power)	21
Model 850 Circuit Board Component Layout (AC Power).....	22
B. Model 220 Alarm (Optional)	23
Model 220 Alarm Board Circuit Diagram.....	23
Model 220 Alarm Board Component Layout	24
C. Pipe Insertion Assembly Dimensions and Materials.....	25
9. WARRANTY	26

1. PRINCIPLE OF OPERATION

A prefocused incandescent lamp directs an intense beam of light through the process fluid. The particulate in the fluid scatters the light in proportion to its concentration. The scattered light is detected by a silicon detector that generates a current signal proportional to the particulate concentration. The electronic signal converter then amplifies and scales the current signal to provide a linear readout on a digital meter and an isolated output signal.

The instrument is "peaked" to operate in the near infrared (NIR) radiant energy spectrum to eliminate errors due to visible colors in the particulate and the process liquid.

The silicon detector is positioned at right angles to the light beam so that true nephelometric readings are obtained. The detector's wide viewing angle provides a measurement that is least affected by particle shape variations. Key components of the sensing head are shown in Figure A below.

The sensor's unique design reduces the effects of stray light and moderate window obscuration, and its short optical path provides a linear response over a wide dynamic range of turbidity.

Figure A

Key Components of Sensor Head

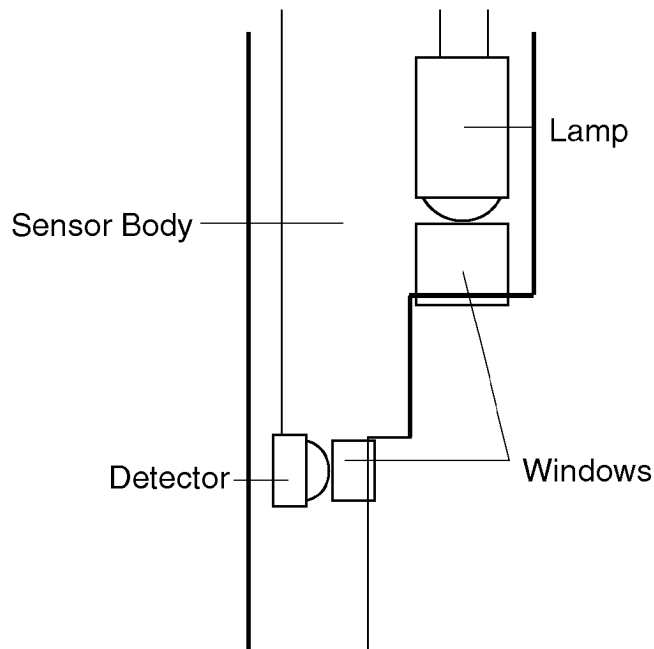

2. INSTALLATION

A. Insertion-Type Sensor

Dimensions

Figure B below shows the dimensions of the insertion-type sensor.

Figure B

Insertion-Type Sensor Dimensions

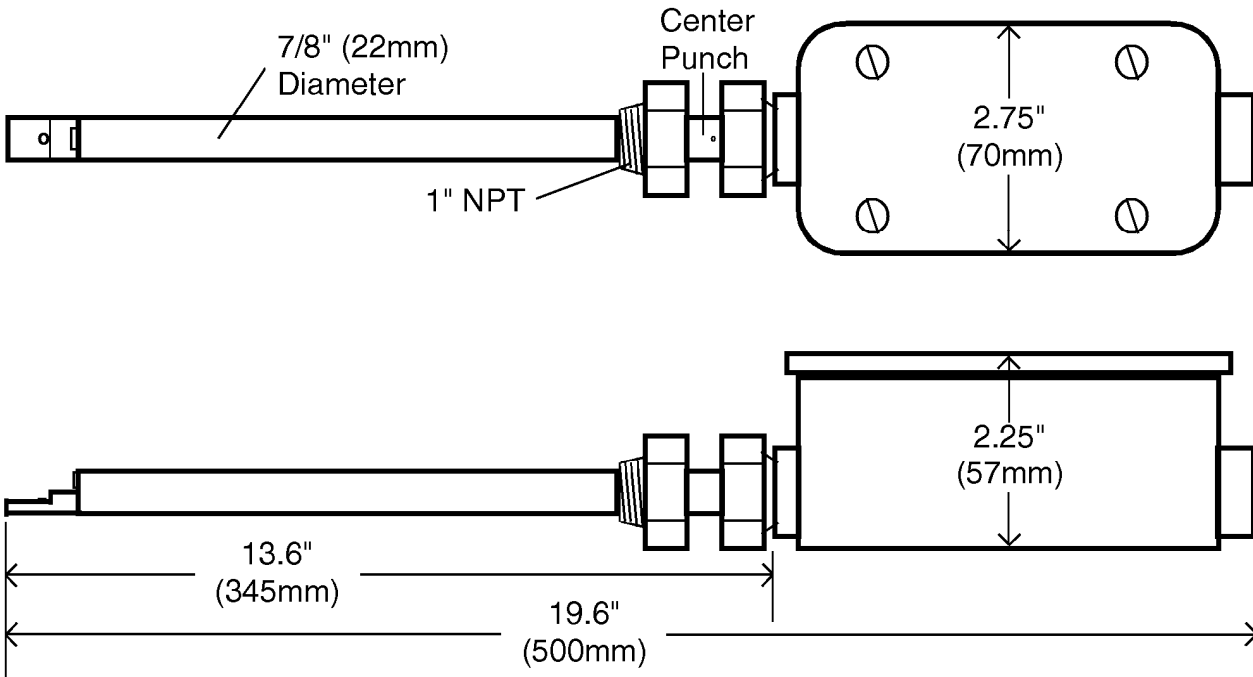

Line Size: There are no restrictions on the maximum pipe diameter into which the sensor can be installed. However, if a 2-inch or smaller line is to be monitored, install a 2-inch or larger "T" to prevent the sensor from blocking the line (see Figure C on page 3 for drawings of typical installations).

Figure C

Typical Sensor Installations

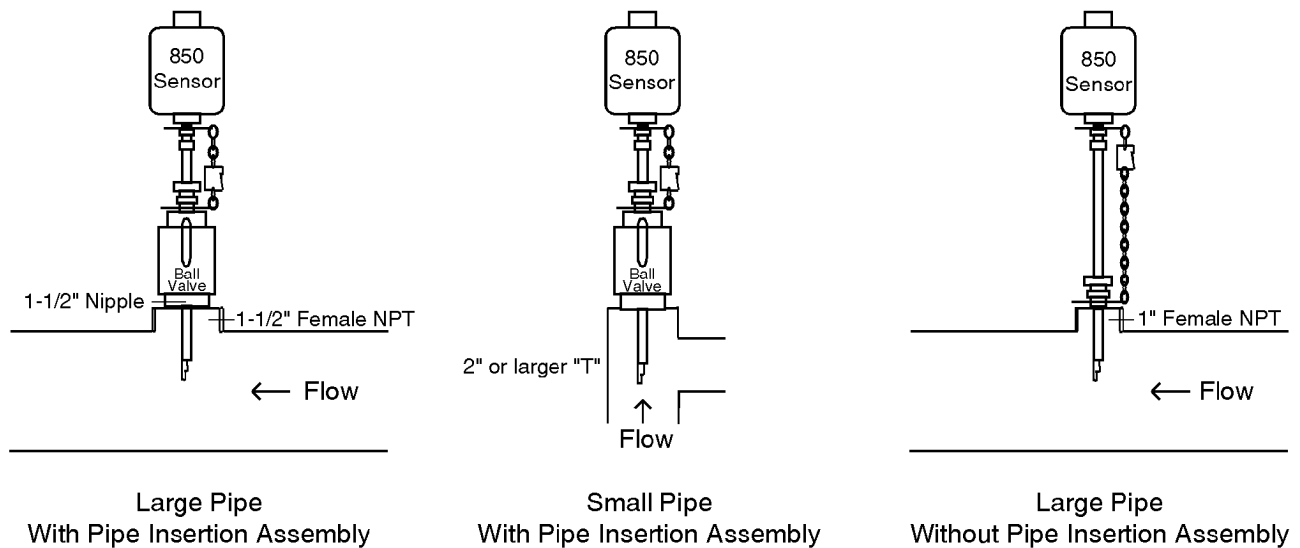

Transparent Lines: If the sensor is to be used in a transparent (e.g., glass, PVC, acrylic, etc.) process or sample line, the pipe must be wrapped with tape to prevent ambient light from entering the pipe and affecting the readings. Wrap the pipe five (5) pipe diameters from the sensor. **Black PVC electrical tape will not block light sufficiently.** Use an aluminum tape or wrap any tape over a metallic foil.

Temperature: The sensor should not be exposed to a process temperature that is below -10°C or greater than 110°C .

Pressure: The sensor should not be used where the process pressure is greater than 150 psig (10 BAR). **A safety chain is provided and MUST be used (see Insertion below).**

Entrained Gas: Gas bubbles in suspension can cause errors, so care should be taken to locate the sensor upstream of anything that could create a pressure drop (e.g., orifice plates, valves, pumps, etc.) and cause the dissolved gases to come out of solution.

Mounting (without pipe insertion adapter): While any position on the periphery of the process pipe may be used to install the sensor, a position above the horizontal plane is recommended, particularly if the sensor is to be removed frequently. The sensor may either be installed through a "T" or a weldment that has been installed on the process pipe. The "T" or weldment must provide a 1" NPT female thread. After mounting the "T" or weldment, thread the male Swagelok fitting supplied with the instrument into the "T" or weldment. Be sure that the large washer with one end of the safety chain fastened to it is captured between the Swagelok fitting and the process pipe.

Mounting (with pipe insertion adapter): While any position on the periphery of the process pipe may be used to install the sensor, a position above the horizontal plane is recommended, particularly if the sensor is to be removed frequently. The sensor may either be installed through a "T" or a weldment that has been installed on the process pipe. The "T" or weldment must provide a 1" NPT male thread. After mounting the "T" or weldment, thread the ball valve supplied with the instrument into the "T" or weldment.

Insertion

An insertion depth between 1" and 4" is suggested. If the process pipe is empty or filled with a clean fluid, position the sensor at a depth where a minimum reading is obtained on the meter. This is to assure that any internally reflected light from the process piping can be zeroed out. To further reduce internally reflected light, rotate the sensor so that the small center punch located below the junction box is facing upstream. In other words, if the process pipe is horizontal and the sensor is inserted into the top of the pipe, the center punch should be facing in line with the flow towards the upstream side. This permits a "scrubbing" action on the windows, and helps eliminate any buildup on the sensor while keeping reflected light at a minimum. Figure C on page 6 shows how to position the sensor. When the sensor has been positioned satisfactorily, firmly tighten the Swagelok fitting so that the sensor cannot be pulled out or rotate. Make sure that the large washer that holds one end of the safety chain is captured between the Swagelok fitting and the process pipe.

AFTER PROPERLY INSTALLING THE SENSOR AND BEFORE THE LINE IS PRESSURIZED, TAKE ALL THE SLACK OUT OF THE SAFETY CHAIN BY MOVING THE "CLIP" TYPE LINK UNTIL THE SAFETY CHAIN IS TAUT.

Junction Box: Route the cable from the electronic signal converter through the sealing gland, and tighten it to assure a moisture-tight seal. Make the wire connections as shown in **Figure G** on page 14 and reinstall the cover and gasket to assure a weather-tight seal. It is important that the inside of the junction box be kept dry at all times. If the junction box is positioned so that it is difficult to make the wire connections, the box may be rotated by loosening the Swagelok fitting immediately under the box.

NOTE: Do not rotate the box more than 180 degrees in either direction or the internal wiring may be damaged. Be sure to retighten the Swagelok fitting.

This completes the installation of the sensor.

Removal

Should it ever become necessary or desired to remove the sensor from the process line, please observe the following steps:

If the sensor has been installed without the pipe insertion adapter and ball valve, the process line will have to be depressurized and probably drained. The sensor may then be safely removed by disconnecting the safety chain and loosening the Swagelok fitting.

If the sensor has been installed using the pipe insertion adapter and ball valve, and it is not possible or practical to de-pressurize the line, **extreme care** must be taken to assure that the sensor is not "blown out" by the process pressure when the Swagelok fitting is loosened. Please follow these steps:

1. Loosen the safety chain one or two links by moving the "clip" towards the process pipe.
2. Loosen the Swagelok fitting sufficiently to permit pulling the sensor out to the new limit of the safety chain.
3. Retighten the Swagelok fitting and repeat steps 1 through 3 until the sensor is clear of the ball valve.
4. Close valve and withdraw sensor completely.

NOTE: NEVER STAND IN FRONT OF THE SENSOR WHILE ATTEMPTING TO REMOVE IT FROM A PIPE THAT IS UNDER PRESSURE.

B. Submersible-Type Sensor

Dimensions

Figure D below shows the dimensions of the submersible-type sensor.

Figure D

Submersible-type Sensor Dimensions

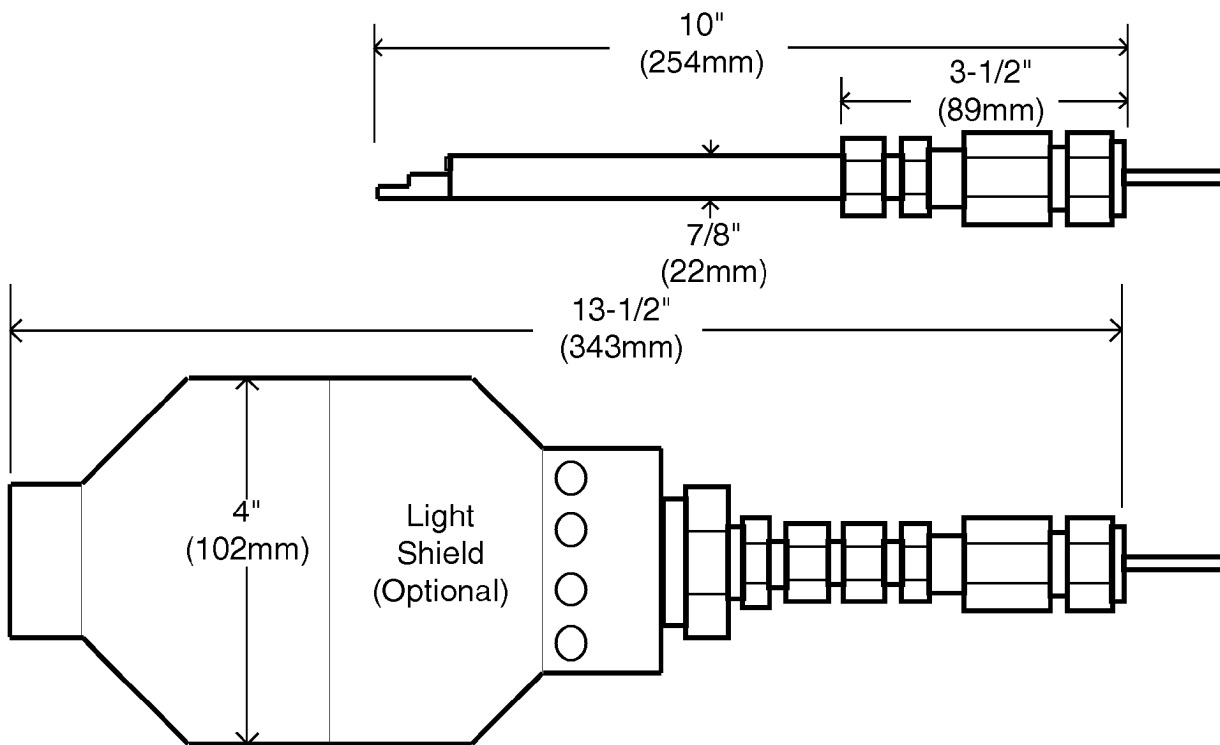

Installation

The sensor may be installed in tanks, clarifiers, streams, lakes, etc. by using any suitable support, or it may simply be suspended using the connecting cable.

Ambient Light Effects: Unless the sensor is to be installed in a completely enclosed light-tight container the optional light shield should be used.

Temperature: The sensor should not be exposed to a process temperature that is below -10°C or greater than 60°C .

Pressure: The sensor should not be exposed to pressures greater than 50 psig (115 feet of water). Sensors capable of handling higher pressures are available by special order.

Entrained Gas: Gas bubbles in suspension appear as particulate, so care should be taken to locate the sensor where there are no bubbles.

C. Electronic Signal Converter

Dimensions

See **Figure E** below for panel/wall mount enclosure dimensions, and **Figure F** on page 8 for the NEMA 4X (watertight) enclosure mounting dimensions.

Environment: The panel/wall mount enclosure must be situated in a dry area. The NEMA 4X enclosure is suitable for wall or pipe mounting and relatively harsh or damp atmospheres. Ambient temperatures should be between 0°C and 50°C.

Figure E

Panel Mount Enclosure Dimensions

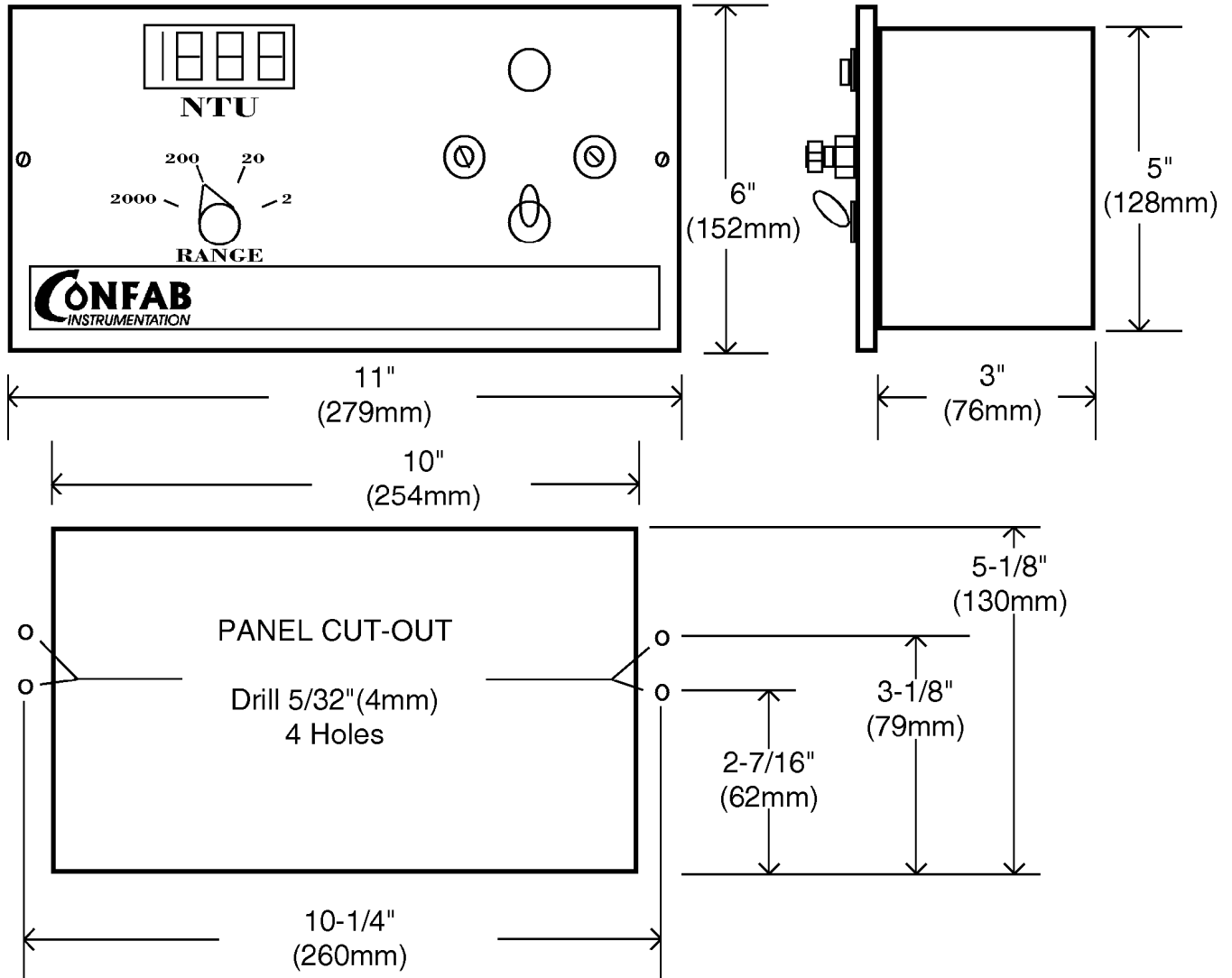
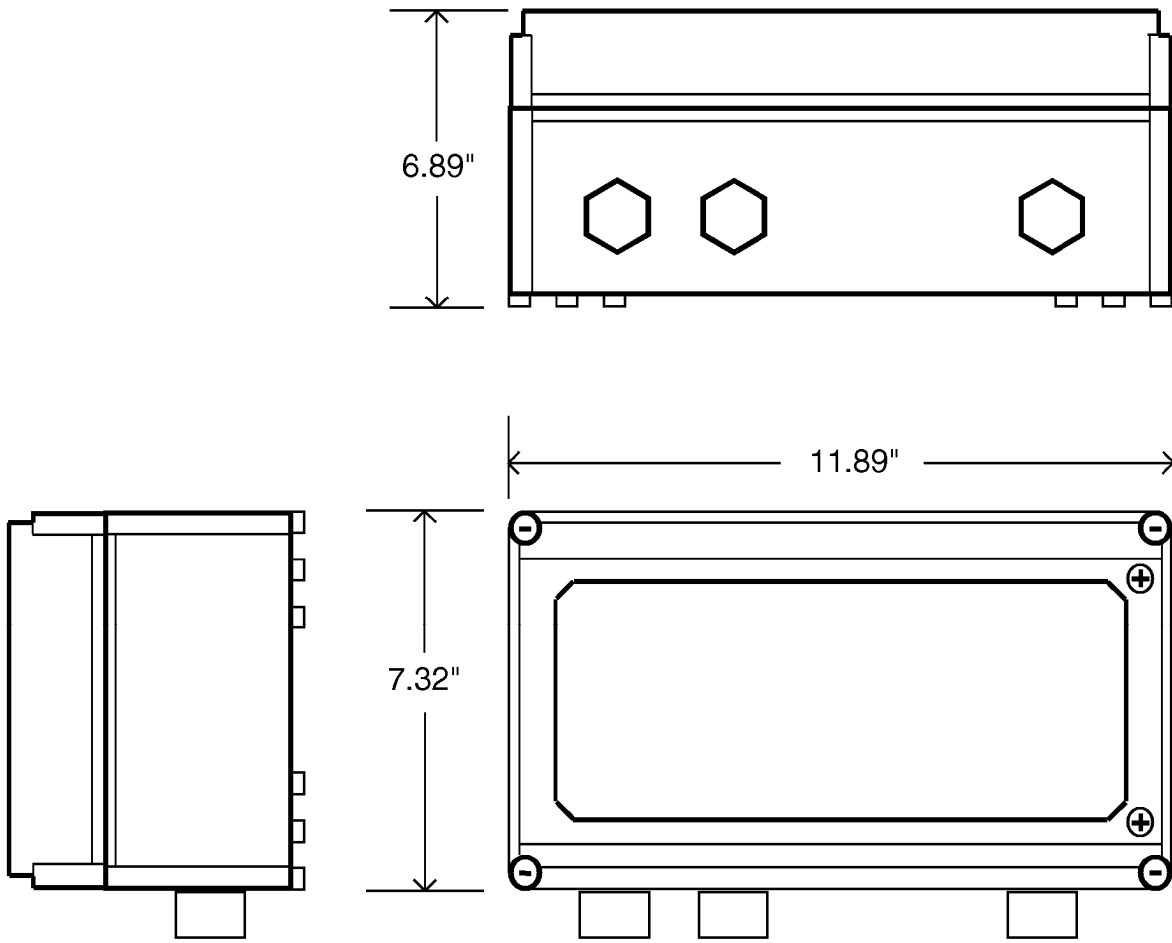

Figure F

Nema 4X Enclosure Dimensions



3. WIRING

A. General

1. All wires should be routed away from potential RF (radio frequency) sources and large inductive loads.
2. All wiring connections at the sensor and the electronic signal converter must go through the sealing glands, and the glands must be tightened sufficiently to keep moisture out. Unused holes in the enclosure should also be sealed.
3. Assure that the interconnecting cable between the sensor and the signal converter is correctly installed (see **Figure G** on page 14) and all terminals are tightened. **Use only the cable supplied with the instrument.** Standard cable length is 25 feet. Optional lengths up to 1000 feet are available.
4. Before connecting the main power at terminals 7, 8, and 9, be sure that the supplied voltage matches the jumper configuration as shown in **Figure G** on page 14.
5. Wire the transmitter output with a shielded twisted pair to terminals 3 and 4 and ground the shield **AT ONE END ONLY.**

NOTE: RFI (Radio Frequency Interference) and large inductive loads such as motors, solenoid valves and large switches can affect the operation of the instrument. Therefore, both the sensor and the Electronic Signal Converter should be properly grounded to eliminate the effects of RFI. If the instrument is mounted in the vicinity of any large inductive loads, all interconnecting cable should be installed in conduit that does not contain power cables.

B. Wiring Diagram

Figure G
Wiring Diagram

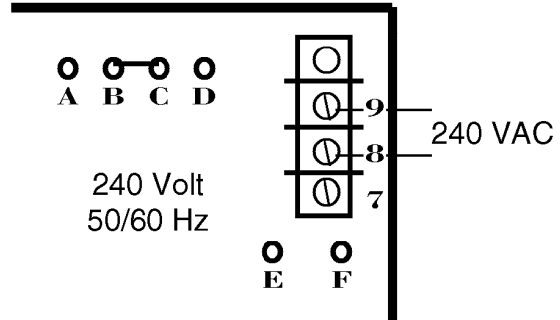
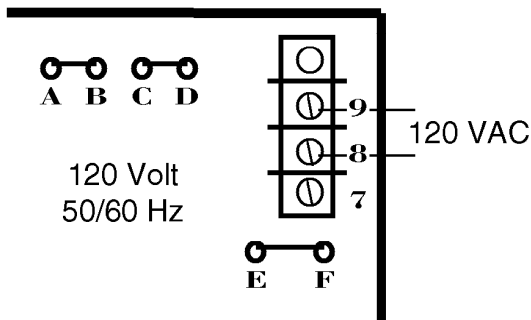
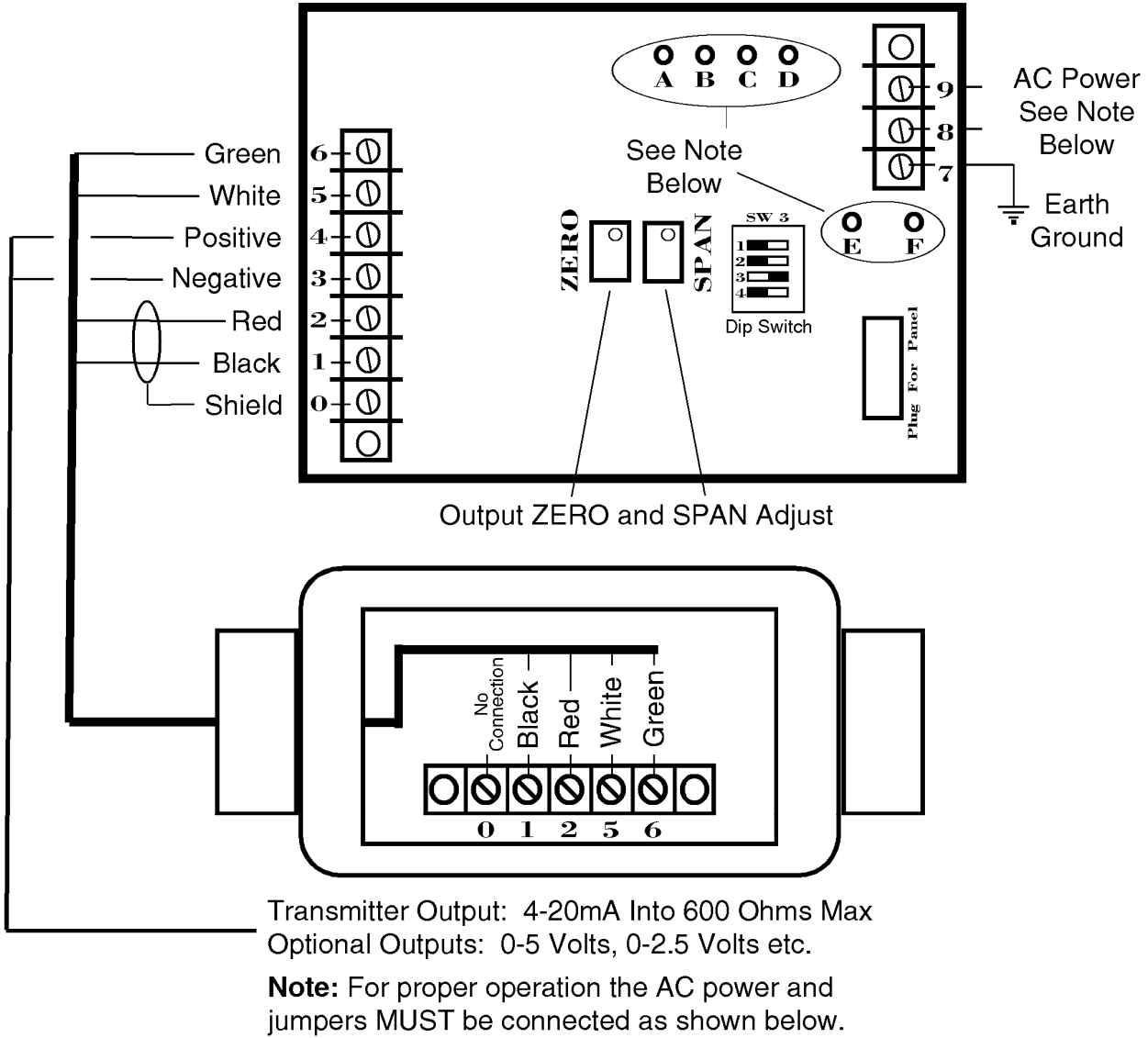

DC Power Connections: For 12V or 24V DC-powered operation, make all connections as above except for power connections. Connect **DC Positive (+) to terminal 9** and **DC Negative (-) to terminal 8**. The jumpers are factory set and do not need adjustment. Be sure that there is a good **earth-ground to terminal 7**.

C. Alarm Unit Connections and Adjustments (Optional)

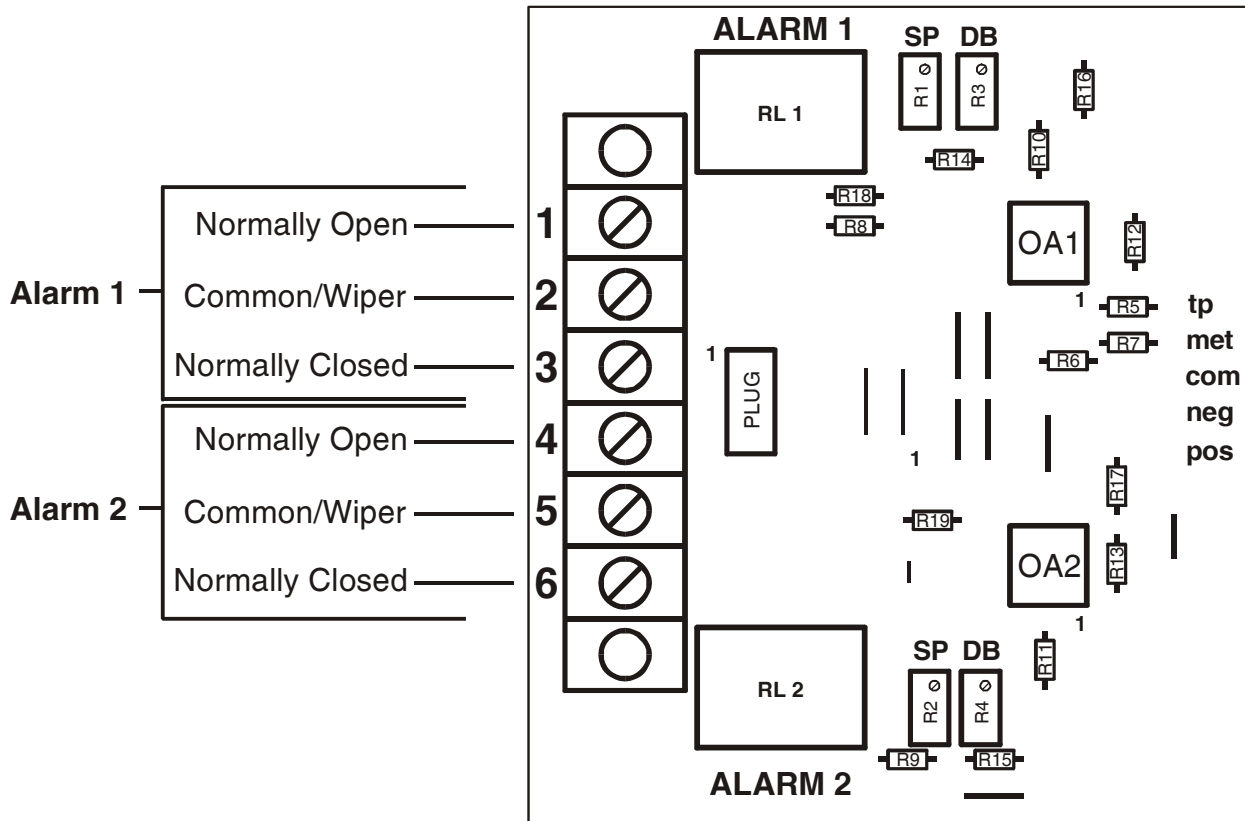

1. Alarm Contact Ratings: 10 Amps @ 120 VAC
2. All adjustments are “clockwise increase”
3. Both alarm trip points are adjustable over the full output range.
4. Alarm trip dead band (DB) adjustments provide a dead band (differential between on and off) of either alarm trip from 0 to 10% of span.

* SP = Alarm trip setpoint adjustment

* DB = Dead band adjustment

4. CALIBRATION

A. General

The Model 850 has been factory calibrated using precise turbidity standards. Calibration standard solution is available directly from GFS Chemicals using the links below or by calling 877-534-0795 (U.S. and Canada) or 740-881-5501 (International). We recommend that you purchase a minimum volume of 500ml.

0 NTU Standard

http://www.gfschemicals.com/statics/productdetails/AMCO_CLEAR_TURBIDITY_STANDARD_8000.html
(500ml use SKU 85004, 1L use SKU 85005, 1gal use SKU 85006)

10 NTU Standard

http://www.gfschemicals.com/statics/productdetails/AMCO_CLEAR_TURBIDITY_STANDARD_8014.html
(500ml use SKU 85065, 1L use SKU 85063, 1gal use SKU 85067)

100 NTU Standard

http://www.gfschemicals.com/statics/productdetails/AMCO_CLEAR_TURBIDITY_STANDARD_8021.html
(500ml use SKU 85095, 1L use SKU 85092, 1gal use SKU 85097)

1000 NTU Standard

http://www.gfschemicals.com/statics/productdetails/AMCO_CLEAR_TURBIDITY_STANDARD_8030.html
(500ml use SKU 85125, 1L use SKU 85122, 1gal use SKU 85126)

On the front panel of the instrument there is a 4-position calibrated range dial. The four calibrated ranges are: 0-2 NTU, 0-20 NTU, 0-200 NTU and 0-2000 NTU. Since there may be differences in the amount of reflected light depending on the pipe line size into which the sensor is installed, it is necessary when starting up the instrument to perform a zero calibration check to ensure maximum accuracy in your turbidity readings.

NOTE: The maximum error due to reflected light should be no more than 5 NTU. If the range in which you are operating is sufficiently high so that a 5 NTU possible error is inconsequential, you may wish to ignore the zero calibration check.

The zero calibration check is to be done after the sensor has been installed in your pipeline. If an accurate laboratory nephelometer is available and a representative sample of the process fluid can be taken, then please **follow PROCEDURE A**. If a laboratory nephelometer is not available, please **follow PROCEDURE B**.

Procedure A

1. Set the range dial to the appropriate position for your process fluid.
2. Take a representative grab sample of your process fluid and simultaneously note the meter reading on the Model 850.
3. Determine the NTU value of the grab sample with a lab nephelometer.
4. Subtract the nephelometer reading from the meter reading to obtain the "difference".

5. Note the present reading on the instrument and adjust the ZERO pot (on the front panel) to correct the instrument reading. If the "difference" is negative, meaning the meter reading is too low, turn the ZERO pot clockwise to increase the reading. If the "difference" is positive, meaning the meter reading is higher than the actual reading obtained by the nephelometer, adjust the ZERO pot counterclockwise to decrease the meter reading.
6. After adjustment, tighten the lock nut on the ZERO pot.

EXAMPLE:

1. Range dial set at 0-200 NTU
2. Meter reading when grab sample was taken.... **55.7** NTU
3. Lab nephelometer reading..... **50.2** NTU
4. Difference..... **+5.5** NTU
5. Present meter reading is 56.5 NTU. Turn the ZERO pot until the meter reads 51.0 (56.5-5.5=51.0). Note that the "difference" is positive (that is, the meter reads too high), so turn the ZERO pot counterclockwise to reduce the reading.
6. Tighten the ZERO pot lock nut.

EXAMPLE:

1. Range dial set at 0-20 NTU
2. Meter reading when grab sample was taken.... **14.7** NTU
3. Lab Nephelometer reading..... **15.9** NTU
4. Difference..... **-1.2** NTU
5. Present meter reading is 14.5 NTU. Turn the ZERO pot until the meter reads 15.7 (14.5+1.2=15.7). Since the "difference" is negative (the meter reads too low by 1.2 NTU), turn the ZERO pot clockwise to increase the reading by 1.2 NTU.
6. Tighten the ZERO pot lock nut.

Procedure B

1. Since a laboratory nephelometer is unavailable, Procedure A cannot be used. However it is assumed that the turbidity of plant or domestic water is known or can be obtained. (NOTE: This is usually about 0.5 NTU)
2. Run plant or domestic water through your process piping and adjust the ZERO pot until meter reads 0.5 NTU, or the known value of your domestic water supply.

NOTE: The above calibration procedures do not require any adjustment of the SPAN pot.

B. Laboratory

This method is normally used on new instruments prior to their installation or on instruments that have been completely removed from the process. Laboratory calibration will require the apparatus as shown in **Figure H** on page 15. The instrument must be wired according to the wiring instructions. During calibration, care must be taken to eliminate all natural light from the sample and sensor tip. Care should also be taken to place the sensor in the middle of the sample chamber to avoid internally reflected light.

To check calibration of the span, it is best to use a sample of around 100 NTU. You will also need a sample of zero-NTU liquid (distilled water). Using the apparatus shown in **Figure H** on page 15, proceed as follows:

1. Set the range dial to the 0-200 position.
2. Place the zero-NTU sample in the sample chamber.
3. Immerse the sensor in the zero-NTU sample, eliminating all the ambient light from the sample chamber. Make sure the sensor is totally immersed in the sample. Never calibrate in direct sunlight.
4. Adjust the ZERO pot on the front panel to read 0.0
5. Remove the 0 NTU sample from the sample chamber, and place the 100 NTU sample in the chamber. Again totally immerse the sensor in the sample, eliminating all the ambient light.
6. Adjust the SPAN pot on front panel until the meter reads 100.0 NTU
7. The span is now calibrated. The range switch can now be set for the desired range.
8. When the instrument is reinstalled in the process line, repeat the calibration Procedure A or Procedure B described on pages 12 and 14 to adjust INSTRUMENT ZERO for reflected light.

Figure H
Laboratory Apparatus

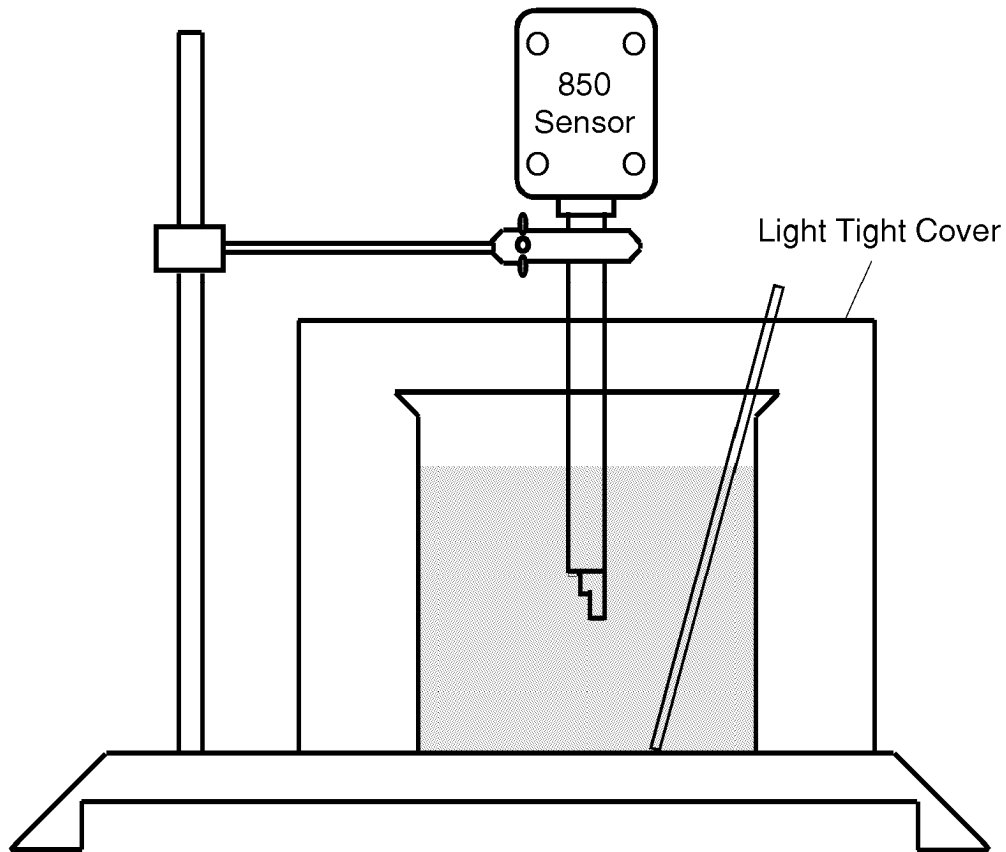

C. Output

The instrument is supplied with either a milliamp (mA) or millivolt (mV) isolated output, corresponding to the range of the instrument. The output is usually specified by the customer at the time of purchase, however if an output has not been specified, a 4-20 mA output will be provided. The output is factory set and should not require any adjustment. If however for some reason the output is found to be out of adjustment, or it is desired to change the output range, recalibrate as follows:

1. The adjustments for the output zero and span are located on the transmitter circuit board (marked ZERO and SPAN).
2. Remove the transmitter front panel, and connect a suitable ammeter that will indicate between 4 and 20 mA DC across terminals **3 (-)** and **4 (+)** in the transmitter.
3. Set the instrument to zero by adjusting the ZERO pot on the FRONT PANEL, then adjust the ZERO pot on the CIRCUIT BOARD until the ammeter reads 4 mA.
4. Next, set the instrument to read the NTU reading for which maximum output is desired, then adjust the SPAN pot on the CIRCUIT BOARD until the ammeter reads 20 mA.

NOTE: To obtain 0 NTU and maximum NTU readings on the instrument digital indicator, it may be necessary to immerse the sensor in samples containing these values.

NOTE: When performing the above output calibration, there may be a small interaction between zero and maximum output, so both points should be rechecked.

NOTE: If a 4-20 mA output is desired for a span that is less than 40% of the value of the range switch setting, it may be necessary to increase the sensitivity of the output. For example, if the range switch is set on 0-200 NTU and an output of 4-20 mA is desired for a span of 0-60 NTU, it will be necessary to adjust span trimpot, SPAN and SW3 (refer to component layout drawing on page 24 for location of these components).

There are 4 DIP switches on SW3. When shipped for normal operation, DIP switch #3 will be "on". For increased sensitivity, use lower-numbered switches.

If a 4-20 mA output cannot be attained for the span desired, slide DIP switch #2 to the "on" position and adjust the SPAN pot on the circuit board to obtain 20 mA reading. If it is still impossible to obtain a 4-20 mA output for the span desired, slide DIP switch #1 to the "on" position and adjust the SPAN pot on the circuit board.

NOTE: Always calibrate the instrument output before calibrating the instrument to the process.

D. Calibration in Units Other Than NTU

The Model 850 has been factory calibrated for NTU (Nephelometric Turbidity Units) readings. If a reading is desired in PPM (parts per million) rather than NTU, samples of known concentration (PPM) and of distilled water (0 NTU) must be prepared (see below). Then a span and zero calibration must be completed following Procedure A or Procedure B described on pages 12 and 14.

NOTE: A 100PPM mixture may be prepared as follows:

- a. Mix 1 gram of the solids from your process with one liter of distilled water.
- b. After mixing well, put 100 ml (100 cc) of the mixture into a one-liter graduate and add distilled water until the one-liter level is reached.

5. SENSOR REMOVAL/REINSTALLATION (w/Insertion Adapter Kit)

NOTE: DO NOT ATTEMPT TO REMOVE THE SENSOR WHEN THE LINE IS FILLED OR UNDER PRESSURE IF THE PROCESS FLUID IS ACIDIC, CORROSIVE, OR AT ELEVATED PRESSURES OR TEMPERATURES!

To remove the sensor from a pressurized line, it is recommended to first depressurize the line and drain it. If this is not possible, then **EXTREME CARE** must be taken to assure that the sensor is not "blown out" by the process pressure when the Swagelok fitting is loosened.

1. Loosen safety chain one or two links by moving the "clip".
2. Loosen the Swagelok fitting enough to permit pulling the sensor out to the new limit of the safety chain.
3. Retighten Swagelok fitting and repeat steps 1 through 2 until the sensor is clear of the ball valve.
4. Close valve.

Sensor Reinstallation: Removal or reinstallation of the sensor should never be attempted when the process fluid is highly acidic or corrosive or at elevated temperatures or pressures. **It is HIGHLY recommended that the process line be depressurized and drained before reinserting the sensor.** If this is absolutely impossible or very impractical, use the following method:

With the ball valve in the "closed" position and the Swagelok tightening gland slightly loosened, insert the sensor into the Swagelok fitting until it stops against the closed portion of the ball. Reconnect the safety chain and remove all slack using the "clip" connector on the chain. **(NOTE: The large washers that are connected to the safety chain must be "captured" between the Swagelok fittings -- one on the valve and on the other on the sensor).** Tighten the Swagelok fitting to a "snug" position, then insert the probe further while containing most of the liquid. While standing to the side of the sensor, **SLOWLY** open the ball valve to permit the liquid to reach the outer Swagelok fitting. When the valve is completely open, insert the sensor to its original position and retighten the Swagelok fitting until it stops leaking. Finally, retighten safety chain to remove all slack, using the "clip" connector on the chain.

6. TROUBLESHOOTING

Problem	Possible Causes	Check/Remedy
No response/meter reading blank	No power Blown fuse Faulty sensor bulb	Check power light. Check fuse. Check to see if sensor lamp is on. If lamp is off, check voltage across terminals 5 & 6 in sensor. If voltage is greater than 11.5 VDC, then sensor has failed.
Meter will not zero (high reading)	Too much scattered light Too much ambient light or too much reflected light Poor sensor connections or incorrect wiring Sensor leads not insulated from body of sensor or conduit Wet connection in converter or sensor housings Defective sensor/transmitter	Remove sensor and place in clean water with a cover to shield ambient light. Disconnect wires on terminals 5 & 6. If meter still will not zero then ambient light is entering pipe. If meter will zero then too much reflected light. Try repositioning the sensor to reduce reflection. Check connections and wiring. Check sensor wires. Look for water or condensate on connections. Remove all sensor wires at transmitter. If meter will not zero turn span full counter clockwise. If meter still will not zero transmitter is bad. If meter will zero then sensor possibly has failed.
Unstable reading	Air bubbles or very large particles in process line RFI pickup Heavy Inductive loads	Take sample and check for bubbles or large particles. If present relocate sensor. Earth ground instrument properly. Mount instrument away from power cables. Put cables in conduit.
Reading does not agree with lab results	Improper calibration Lab procedure error Lab instrument error Defective sensor	Recalibrate instrument. Check procedure. Check instrument. Refer to supplier.
Readings drift with time	Converter not warmed up Sensor/converter connections wet Deposit buildup on sensor	Warm up converter for 15 minutes. Look for water or condensate on connections. Dry connections with hair dryer. Then use NEMA 4X enclosure. Remove sensor and clean.
Negative readings or negative output	Wet or damp connections Faulty sensor bulb	Dry connections with hair dryer. Then use NEMA 4X enclosure. Check to see if sensor lamp is on. If lamp is off, check voltage across terminals 5 & 6 in sensor. If voltage is greater than 11.5 VDC, then sensor has failed.

7. TECHNICAL SUPPORT

If technical support is required, please contact us at the phone number on the front cover, and be prepared to provide the following information:

- _____ **Serial Number** (inside signal converter)
- _____ **Light Gap/Path Length** (1/2.5cm/special)
- _____ **Sensor Type** (Submersible/Insertion)
- _____ **Date Purchased**
- _____ **Output** (Current/Voltage)
- _____ **Power** (110VAC/220VAC/12VDC)
- _____ **Process Temperature**
- _____ **Process Pressure**
- _____ **Process Solid** (Sand/Pulp/Yeast)
- _____ **Process Liquid** (Water/Oil/Alcohol)
- _____ **Process Solid Concentration**
- _____ **Process Piping Material** (ABS/Stainless)
- _____ **Process Piping Size**
- _____ **Anything else you feel is important**

8. TECHNICAL DIAGRAMS

A. Model 850 Turbidimeter

Model 850 Circuit Diagram (DC Power)

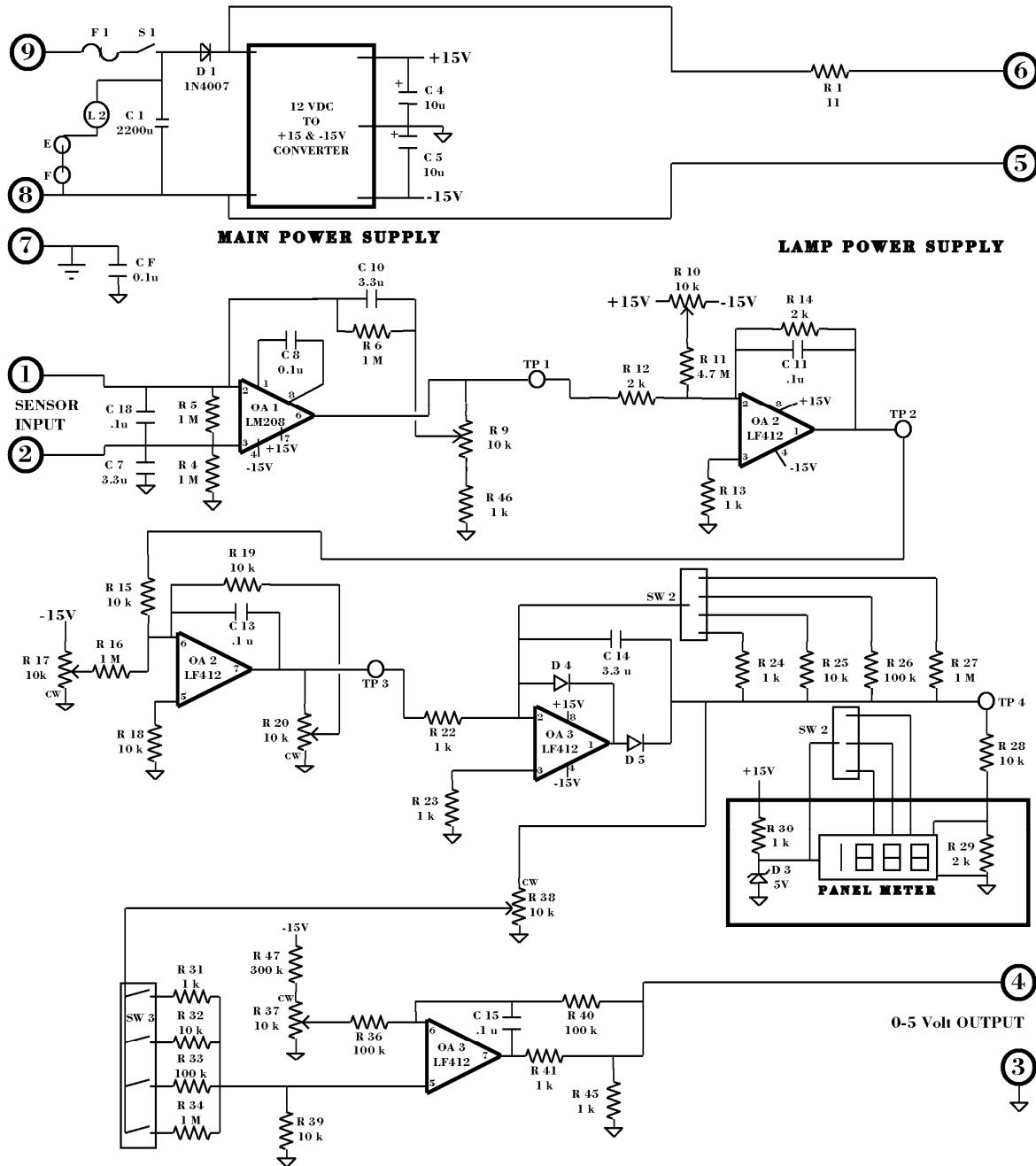

Model 850 Circuit Diagram (AC Power)

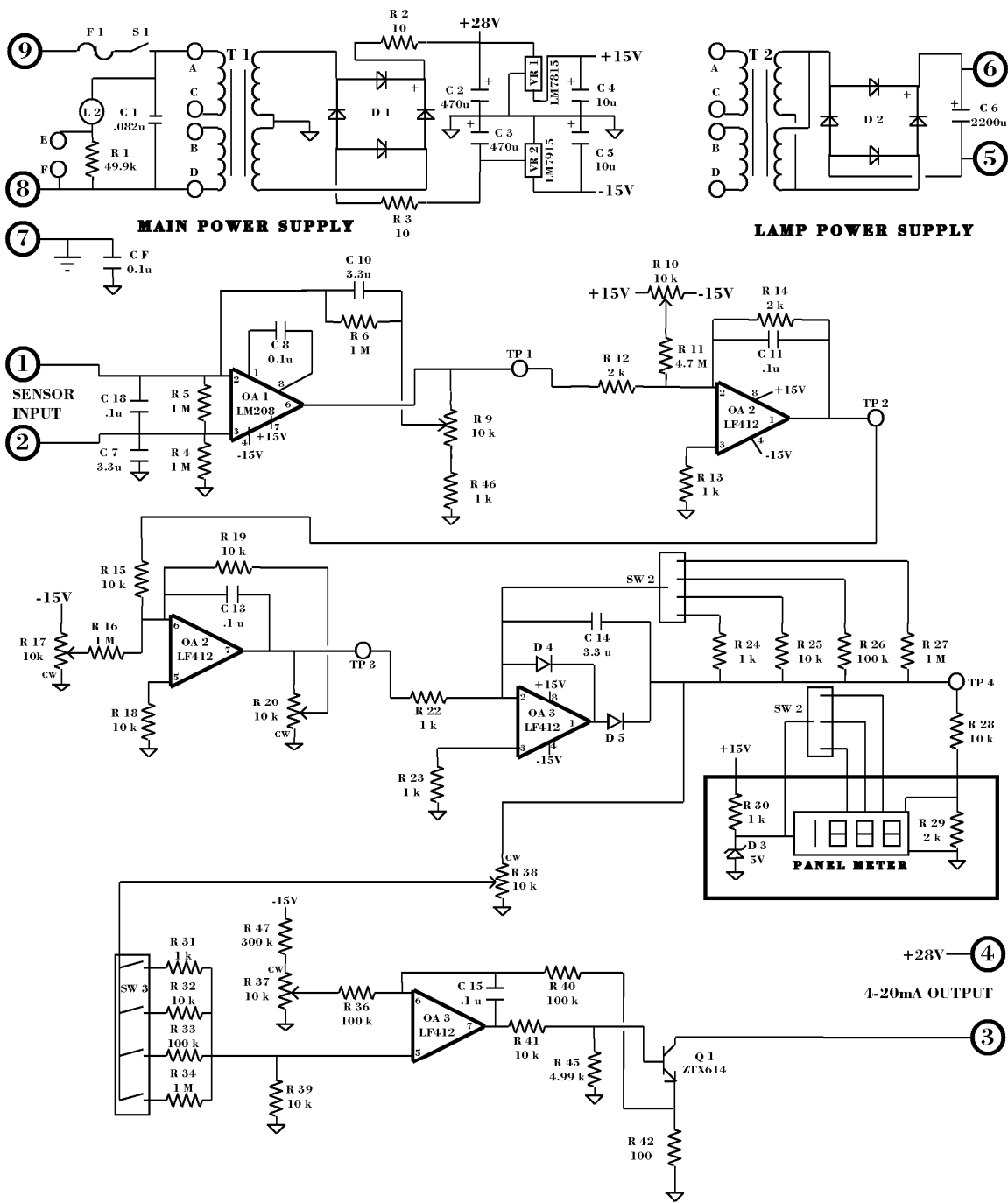

Model 850 Circuit Board Component Layout (AC Power)

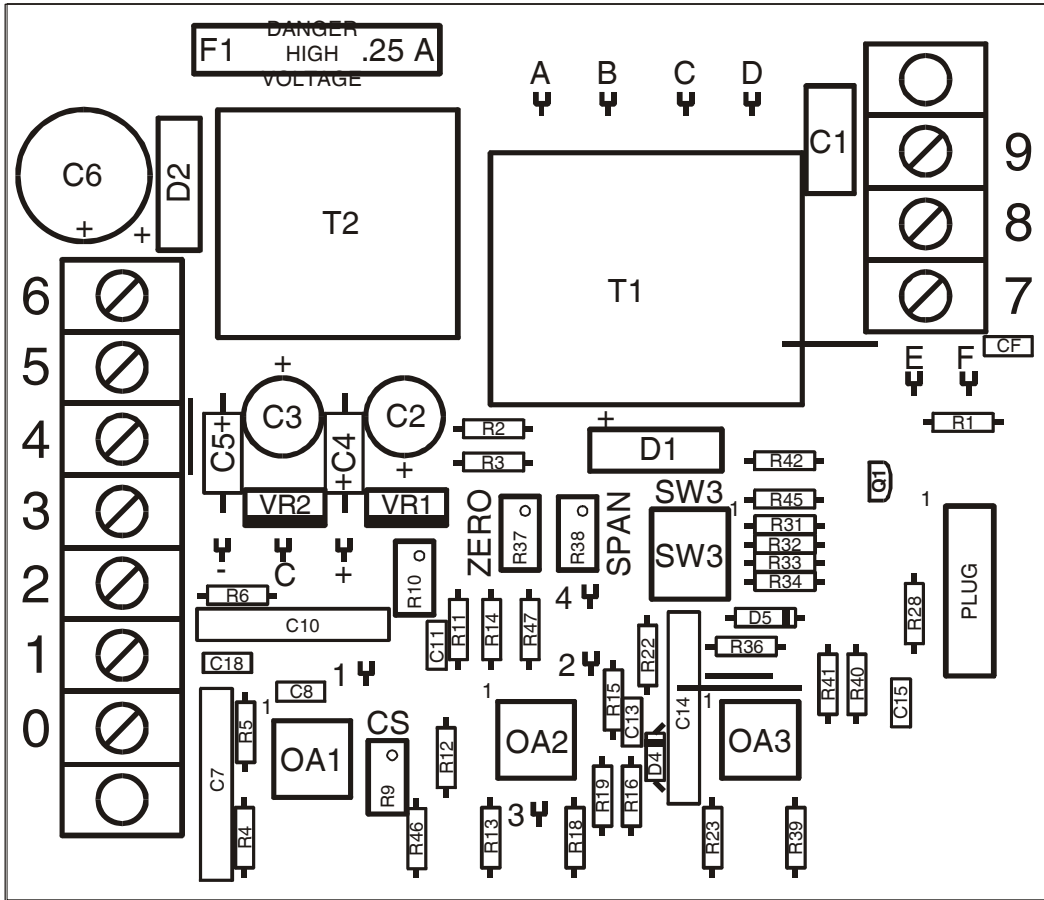

B. Model 220 Alarm (Optional)

Model 220 Alarm Board Circuit Diagram

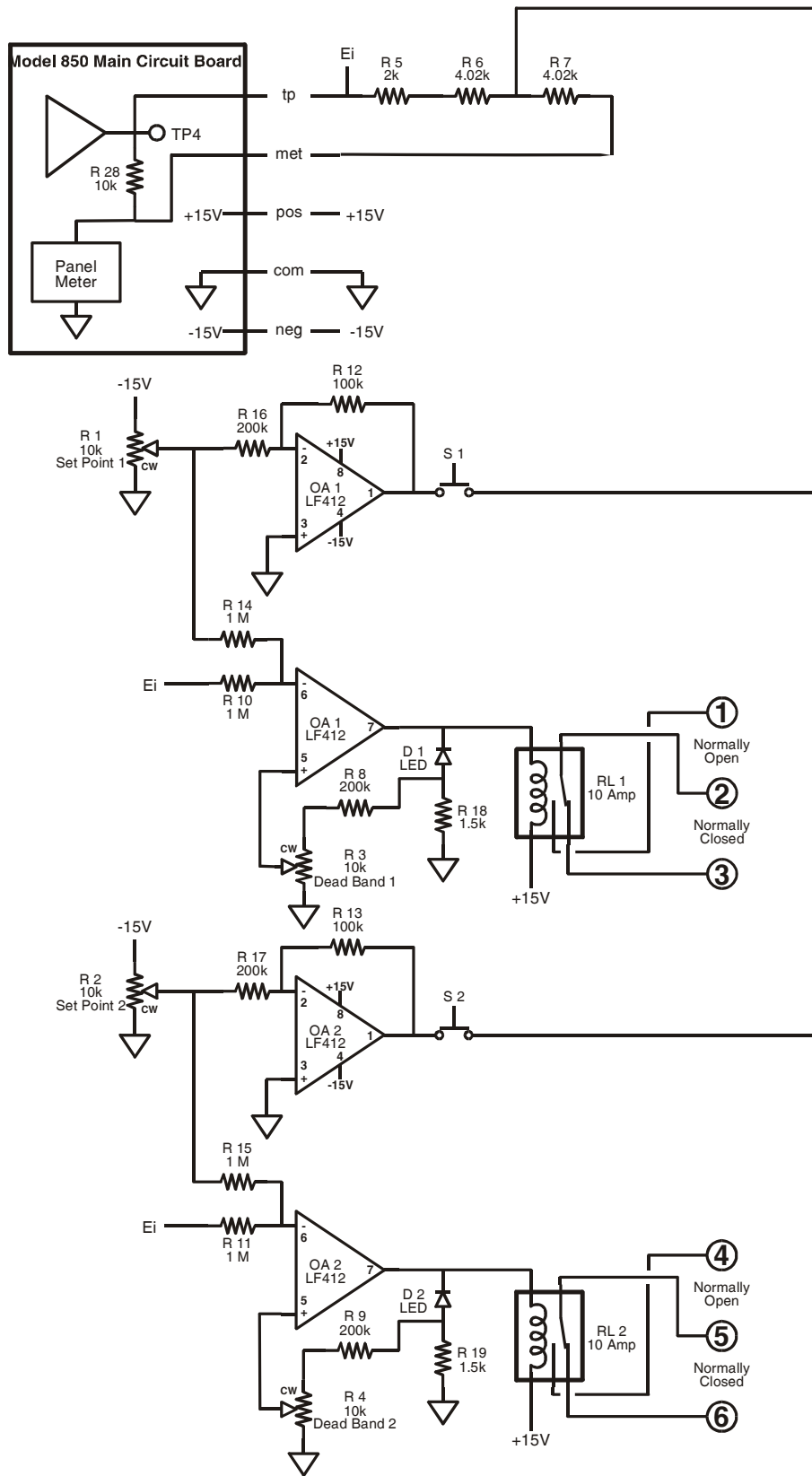

Model 220 Alarm Board Component Layout

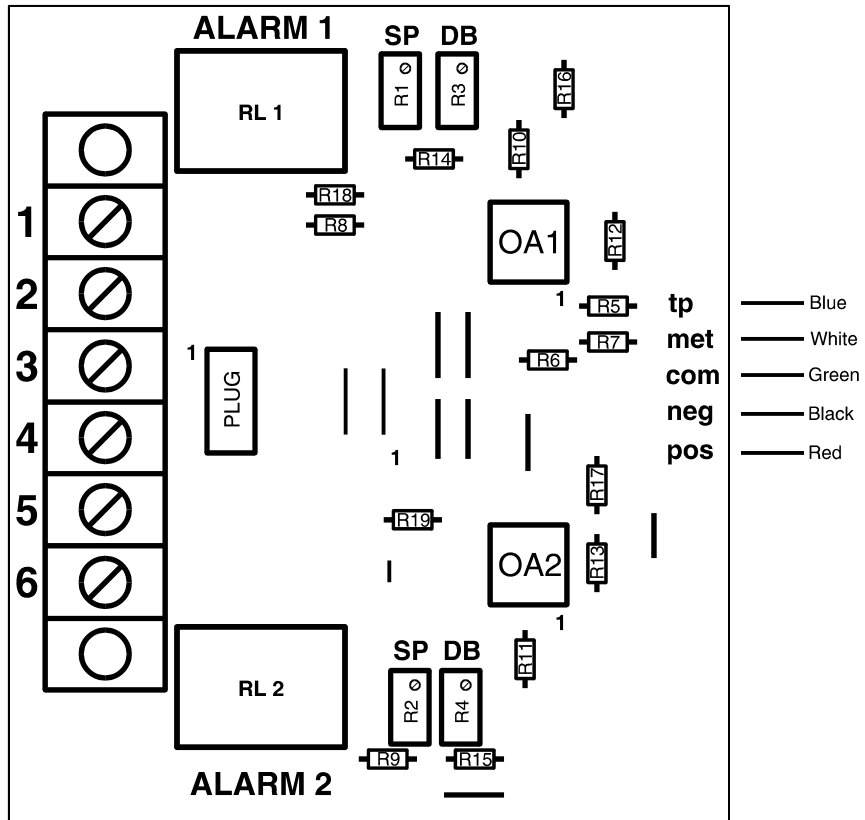

C. Pipe Insertion Assembly Dimensions and Materials

Dimensions:

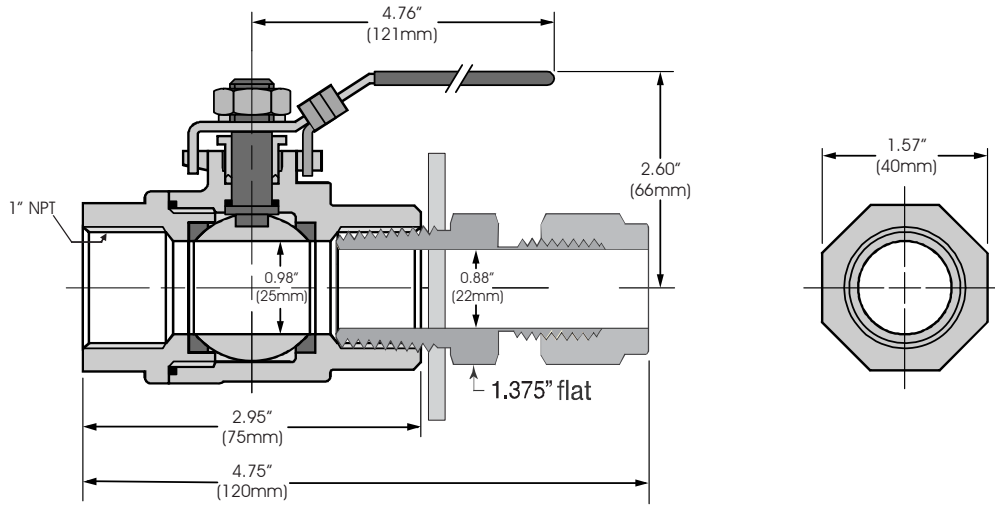

Materials:

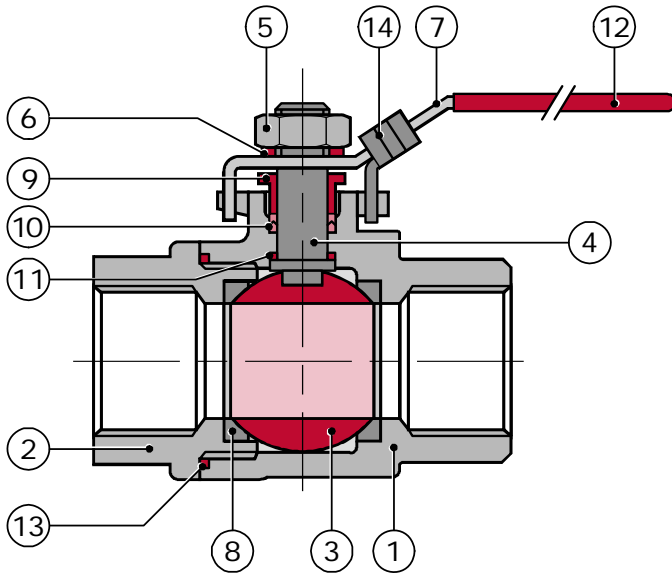

No.	Part	Material	Qty.
1	Body	ASTM A351 Gr. CF8M	1
2	End Cap	ASTM A351 Gr. CF8M	1
3	Ball	AISI 316	1
4	Stem	AISI 316	1
5	Stem Nut	AISI 304	1
6	Stem Washer	AISI 304	1
7	Handle	AISI 304	1
8	Seat	PTFE	2
9	Gland Nut	AISI 304	1
10	Stem Packing	PTFE	1
11	Thrust Washer	PTFE	1
12	Handle Sleeve	Vinyl	1
13	Joint Gasket	PTFE	1
14	Locking Device	AISI 304	1

9. WARRANTY

Confab Instrumentation's products are warranted to be free from defects in material and workmanship for a period of one (1) year from the date of shipment. The final determination as to whether the product has failed due to defects in materials or workmanship rests solely with Confab Instrumentation. Products that have been proven to be defective in workmanship or materials will be repaired or replaced at Confab Instrumentation's facility at no charge to the buyer. Defective instruments must be returned to Confab Instrumentation freight prepaid. **THERE ARE NO IMPLIED WARRANTIES OF MERCHANTABILITY OR OF FITNESS FOR A PARTICULAR PURPOSE GIVEN IN CONNECTION WITH THE SALE OF ANY CONFAB INSTRUMENTATION PRODUCT(S).** In no event shall Confab Instrumentation be liable for consequential, incidental or special damages. The buyer's sole and exclusive remedy and the limit of Confab Instrumentation's liability for any loss whatsoever, shall not exceed the purchase price paid by the purchaser for the product or equipment to which a claim is made.

